

# Service Bulletin

## 001

---

### **Purpose:**

Due to a high number of damaged fuel filter assemblies during fuel filter replacement, an updated service procedure is presented below. Damage will occur to the fuel filter assembly resulting from the use of excessive tightening force or thread misalignment. A damaged fuel filter assembly can leak fuel and pose many risks to the user, equipment, and the environment. This procedure should be strictly followed to avoid damage to the fuel filter assembly.

### **Scope:**

All GreenAPU diesel auxiliary power units equipped with a Perkins/CAT element style fuel filter assembly PN: 130306041.

### **Safety Precautions:**

Wear all appropriate personal protection equipment when performing any work on mechanical and electrical components. GreenAPU recommends a minimum of: safety glasses, work boots, gloves and long sleeved work clothes. Do not wear any loose clothing.

Care must be taken to contain all fluids during performance of inspection, maintenance, testing, adjusting and repairing the fuel filter assembly. Be prepared to collect all fluid with a suitable container before beginning any work.

Dispose of all fluids in accordance to local regulations and mandates.

### **Notes:**

Do not allow dirt to enter the fuel system. Clean all work areas prior to disassembly. Fit suitable covers over disconnected components to avoid contamination.

Keep all parts clean from contaminants. Impurities entering the fuel system may cause rapid wear and damage to mechanical components.

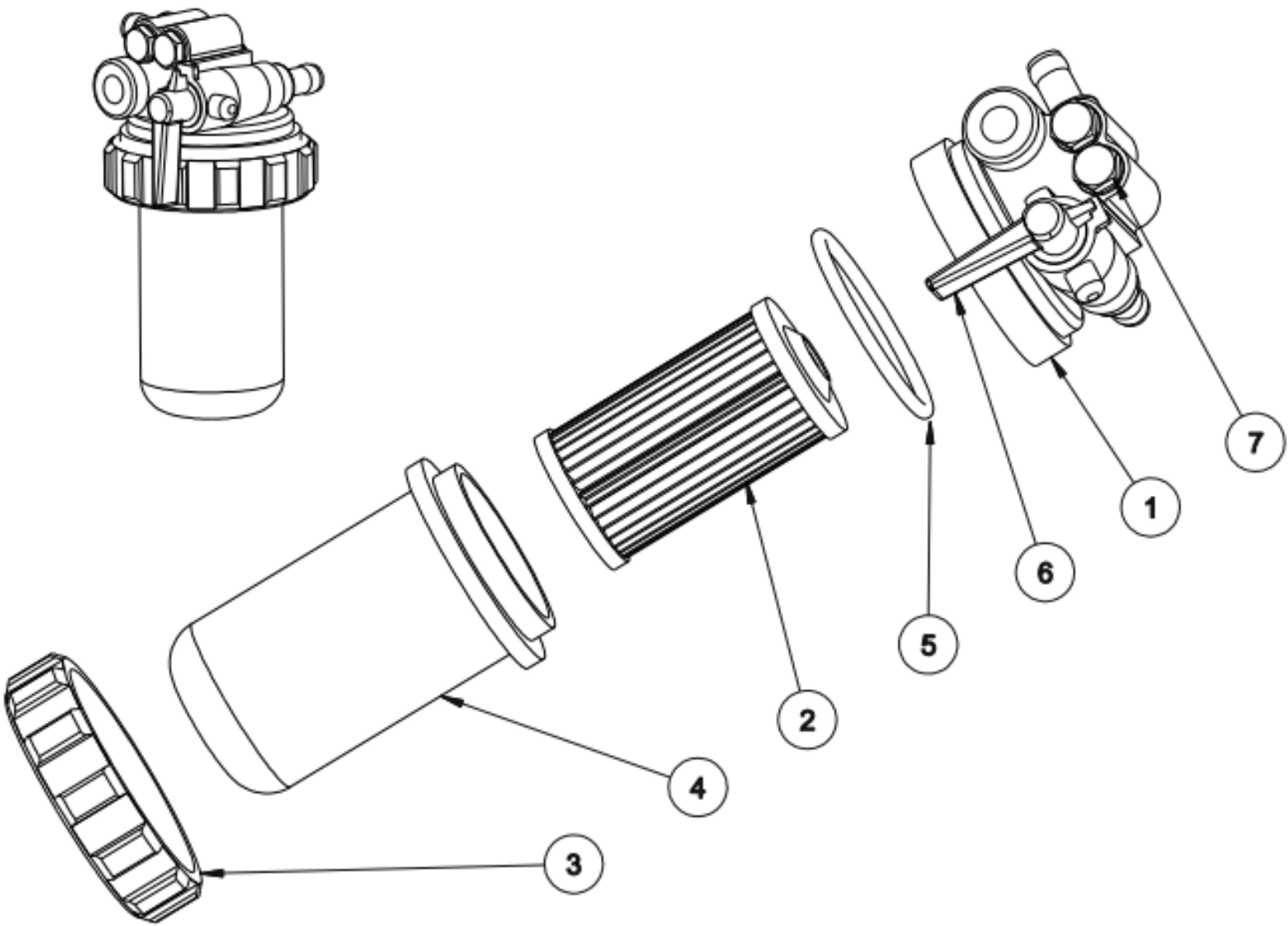

ITEM NO.	PART NUMBER	DESCRIPTION
1	130306041-BASE	BASE
2	GAPU33262	FILTER ELEMENT
3	130306041-LOCKING RING	LOCKING RING
4	130306041-CASING	CASING BOWL
5	130306041-SEAL	O-RING SEAL
6	130306041-VALVE	ON/OFF VALVE
7	130306041-VENT	VENT SCREW

## Fuel Filter Removal

Turn off APU engine and disconnect the positive battery cable leading to the unit in order to prevent starting. On the in-cab controller place a note warning others that the unit is in service.

Clean the outside of the fuel filter assembly before removing any parts.

Place a suitable container under the filter assembly to catch any fluid that may spill.

The on/off valve (6) should be left in the open position. In many cases the valve becomes seized and will be damaged when operated. Instead use hose pinch-off pliers on the inlet fuel line to shut-off fuel.

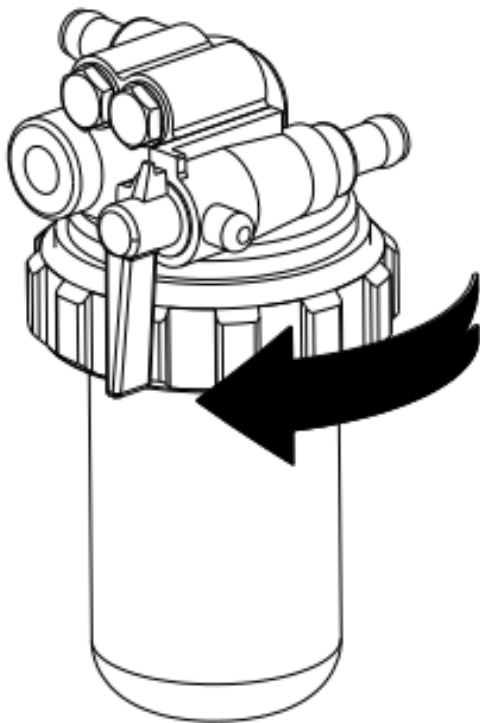

Loosen the locking ring (2) by twisting it in the indicated direction. If the ring is seized use pliers to remove it. Do not use excessive force to remove the lock ring to prevent damage. While supporting the casing bowl (4) against the base (1) to prevent fluid leakage, slip off the locking ring to remove it from the assembly.

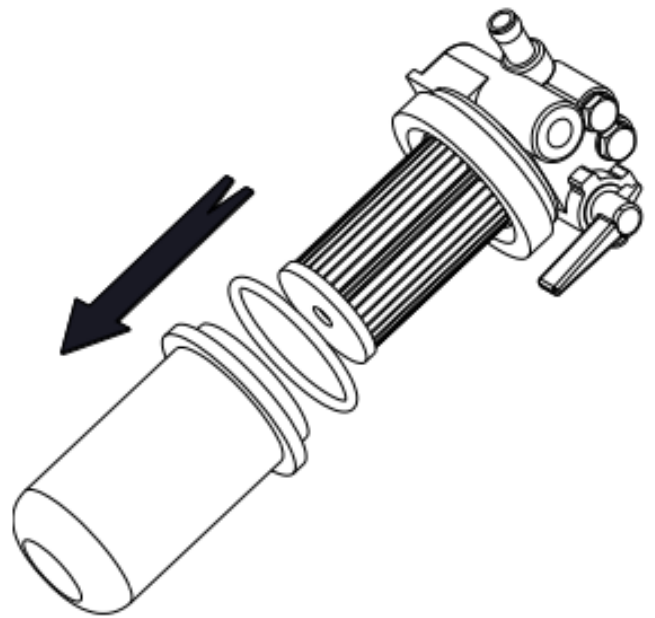

Slide down the casing bowl (4) to expose the filter element (2). Ensure that the O-ring seal (5) is also removed from the assembly.

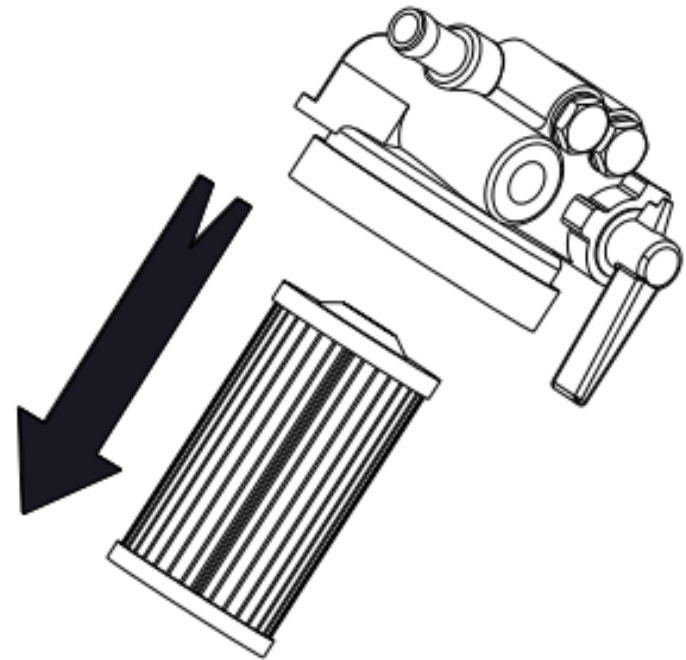

Remove the filter element (2) from the assembly by pulling it downwards. In the event that metal flanges separate from the filter element, ensure they are removed as well.

If left disassembled, place suitable covers over all openings to prevent contamination.

## Fuel Filter Installation

Clean all parts removed in the previous steps. Pay special attention to clean all threads located on the locking ring (3) and base (1).

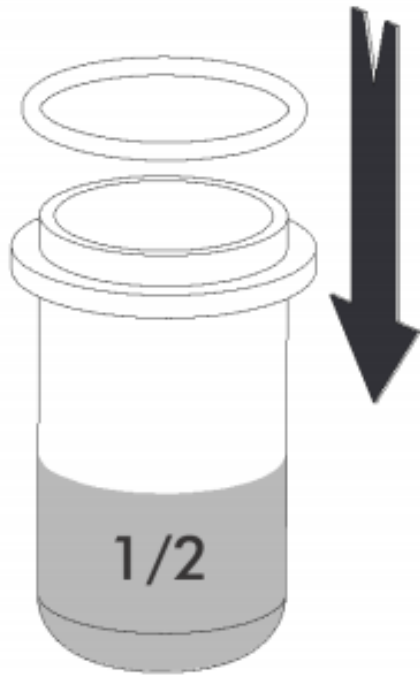

Install the O-ring seal (5) over the casing bowl (4). Seal should have a tight fit, if loose replace the O-ring seal. Fill the casing bowl (4) with clean diesel fuel no more than half way.

Insert a new filter element (2) up into the base (1). Ensure the central opening of the filter is firmly pressed against the base. When installed correctly filter should hang from the base on its own.

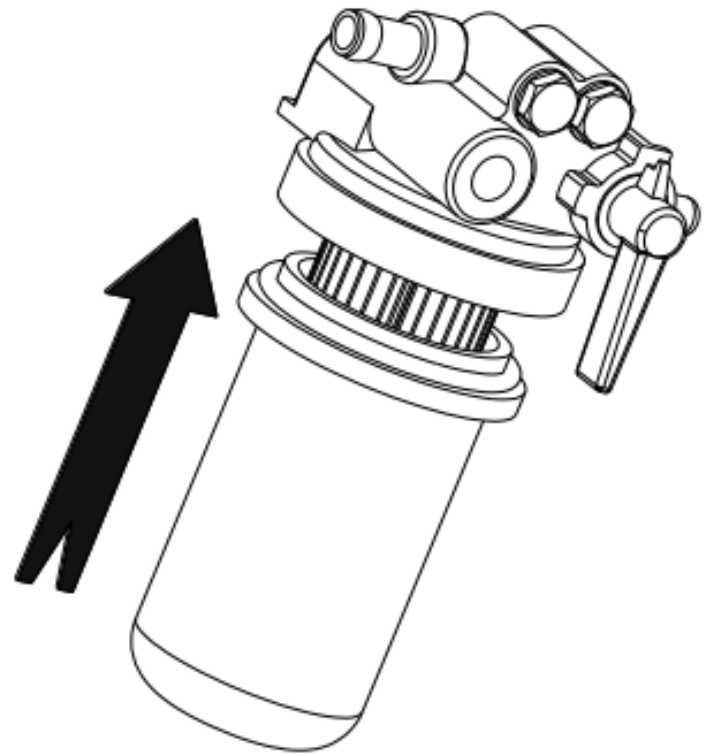

Install the casing bowl (1) fitted with an O-ring seal (5) over the filter. Seal should be seated against the base (1).

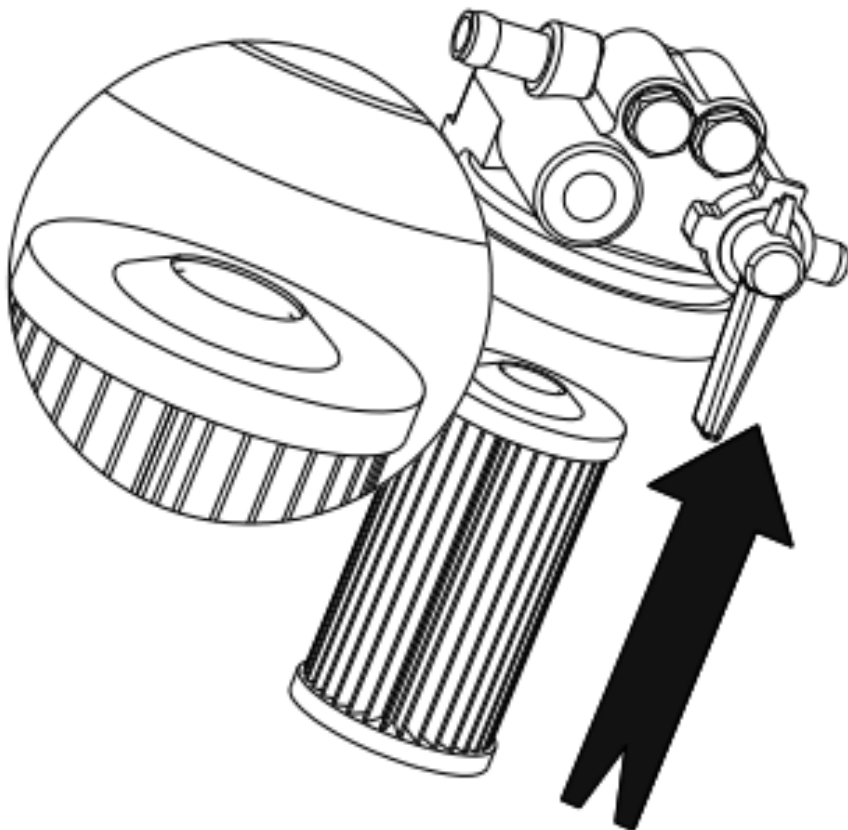

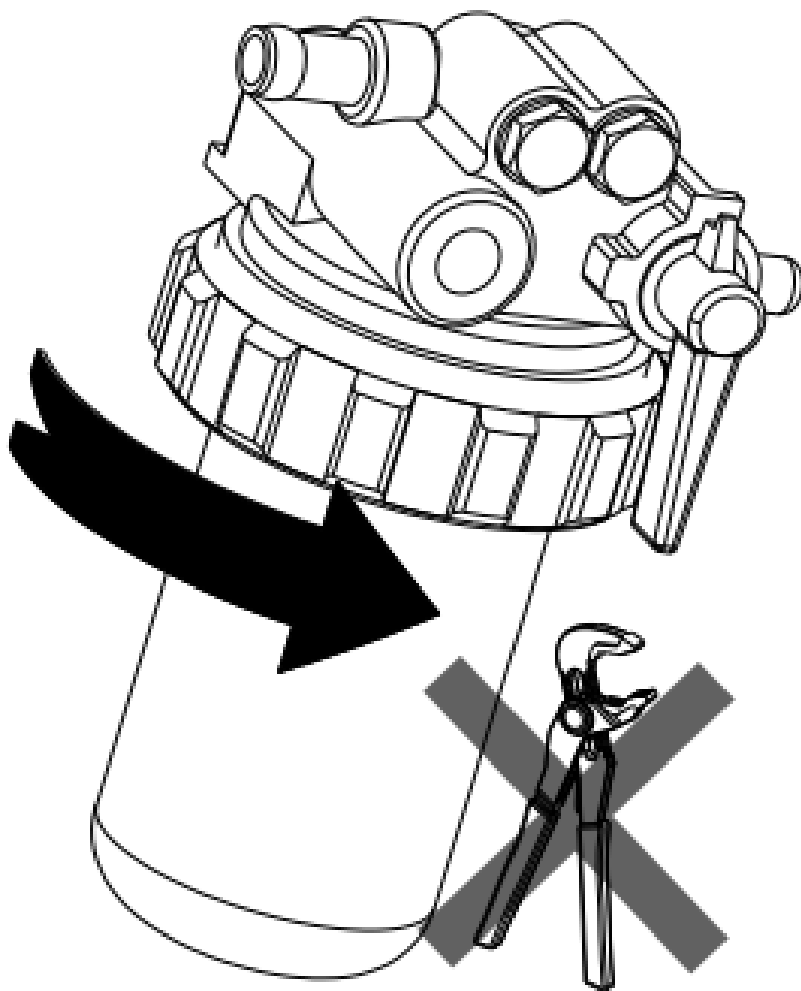

Position the locking ring (3) over casing bowl (4). Take special care in aligning threads and screw on the locking ring finger tight. Ring should turn freely when threads are properly engaged. Tighten the locking ring (4) hand tight. **DO NOT USE PLIERS OR ANY OTHER TOOL TO TIGHTEN THE RING. OVERTIGHTENING THE LOCK RING CAN DAMAGE THE FUEL FILTER ASSEMBLY AND CAUSE FUEL LEAKAGE.**

If used, remove the hose pinch-off pliers to return fuel supply. Reconnect the positive battery cable to the unit and remove note from in-cab controller. APU is ready to start.

## **Fuel System Prime**

After replacing the fuel filter it may be necessary to prime the fuel system.

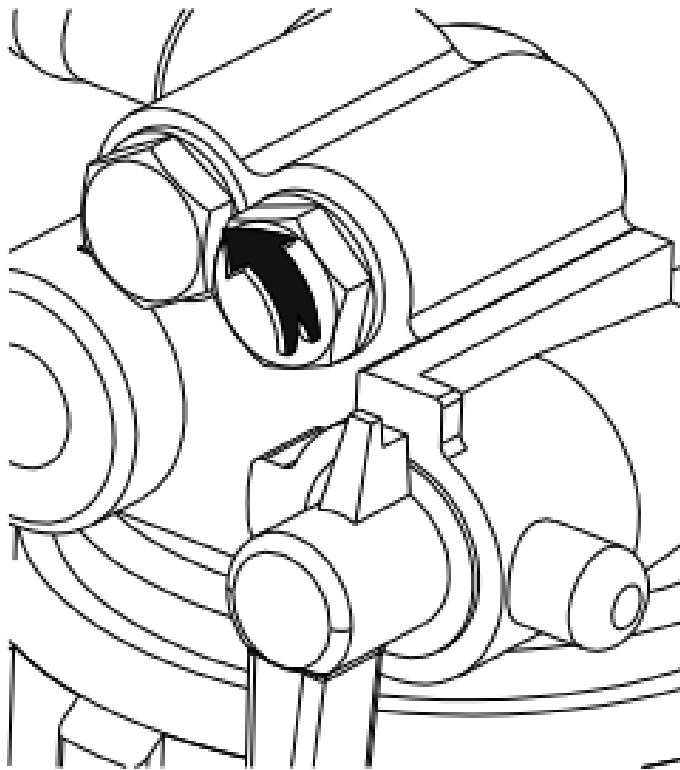

Loosen the vent screw (7) by  $\frac{1}{2}$  turn in the indicated direction. Vent screw should not be completely removed.

Using the in-cab controller start the engine. If air has entered the fuel system it may be necessary to extend the crank time.

Once air-free fuel escapes through the vent port tighten the vent screw (7).

Inspect the whole assembly for leaks.

Shut down the APU using in-cab controller.